

APDS-9008

Miniature Surface-Mount Ambient Light Photo Sensor

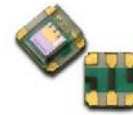

Data Sheet



Description

The APDS-9008 is a low cost analog-output ambient light photo sensor in miniature chipLED lead-free surface mount package. It consists of a spectrally suited photo sensor, which provides excellent responsivity that is close to the response of the human eyes, as show in figure 2. The APDS-9008 is ideal for applications in which the measurement of ambient light is used to control display backlighting. Mobile appliances such as the mobile phones and PDAs that draw heavy current from display backlighting will benefit from incorporating these photo sensor products in their designs by reducing power consumption significantly.

Application Support Information

The Application Engineering Group is available to assist you with the application design associated with APDS-9008 ambient light photo sensor module. You can contact them through your local sales representatives for additional details.

Features

- Excellent responsivity
 - Close responsivity to the human eye
- Miniature ChipLED Leadfree surface-mount package
 - Height – 0.55 mm
 - Width – 1.60 mm
 - Depth – 1.50 mm
- Low sensitivity variation across various light sources
- Operating temperature : -40°C to 85°C
- Vcc supply 1.6 to 5.5V
- Lead-free package, RoHS compliance
- Output linearity across wide illumination range
- High output saturation voltage

Applications

- Detection of ambient light to control display backlighting
 - Mobile devices – Mobile phones, PDAs
 - Computing devices – Notebooks, Webpads
 - Consumer devices – TVs, Video Cameras, Digital Still Camera
- Automatic Residential and Commercial Lighting Management
- Electronic Signs and Signals

Ordering Information

Part Number	Packaging Type	Package	Quantity
APDS-9008-020	Tape and Reel	6-pins Chipped package	2500

Typical Application Circuit

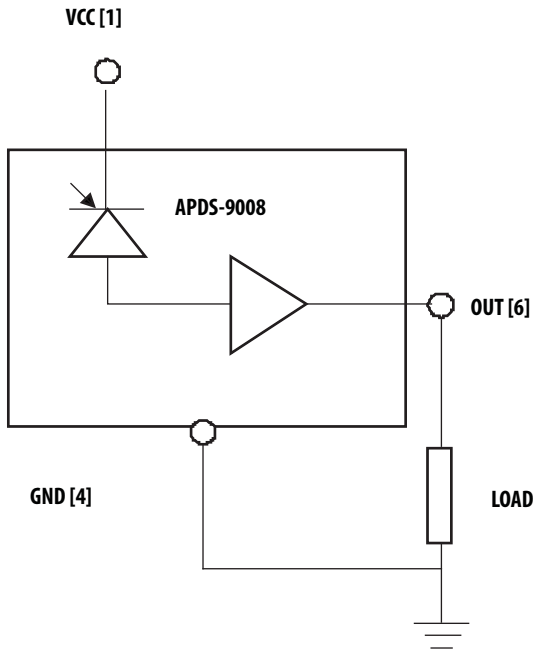

Figure 1. Typical application circuit for APDS-9008

I/O Pins Configuration Table

Pin	Symbol	Description
1	VCC	VCC
2	NC	No Connect
3	NC	No Connect
4	GND	Ground
5	NC	No Connect
6	Iout	Out

Absolute Maximum Ratings

For implementations where case to ambient thermal resistance is ≤ 50 °C /W

Parameter	Symbol	Min.	Max.	Units
Storage Temperature	T_S	-40	85	°C
Supply Voltage	V_{CC}	0	6	V

Recommended Operating Conditions

Parameter	Symbol	Min.	Max.	Units	Conditions
Operating Temperature	T_A	-40	85	°C	
Supply Voltage	V_{CC}	1.6	5.5	V	

CAUTION: It is advised that normal static precautions be taken in handling and assembly of this component to prevent damage and/or degradation which may be induced by ESD.

Electrical & Optical Specifications (Ta=25°C)

Parameter	Symbol	Min.	Typ.	Max.	Units	Conditions
Supply Current	ICC		42		μA	Vcc = 1.8V, Lux = 100 (2)
Photo Current (I)	I _{PH1}	28	40	52	μA	Vcc = 1.8V, Lux = 100 (2)
Photo Current (II)	I _{PH2}		44		μA	Vcc = 1.8V, Lux = 100 (1)
Dark Current	I _{DARK}		300		nA	Vcc = 1.8V, Lux = 0
Light Current Ratio	I _{PH2} /I _{PH1}		1.1			Incandescent light / Fluorescent light
Rise Time	Tr		5		ms	R1 = 1Kohm, Lux = 100
Fall Time	Tf		5		ms	R1 = 1Kohm, Lux=100
Settling Time	T _{set}		10		ms	R1=2.4Kohm,Lux=100
Peak sensitivity wavelength	λ		565		nm	
Propagation delay	Td		5		ms	R1 = 1Kohm, Lux = 100
Storage delay	Ts		5		ms	R1 = 1Kohm, Lux=100
Saturation voltage	Vsat	1.5			V	R1 = 100Kohm, Lux = 100, Vcc=1.8V

Notes :

1. Illuminance by CIE standard light source (Incandescent lamp)
2. Fluorescence light is used as light source, white LED is substituted in a mass production process.

Light Measurement Circuit and Waveforms

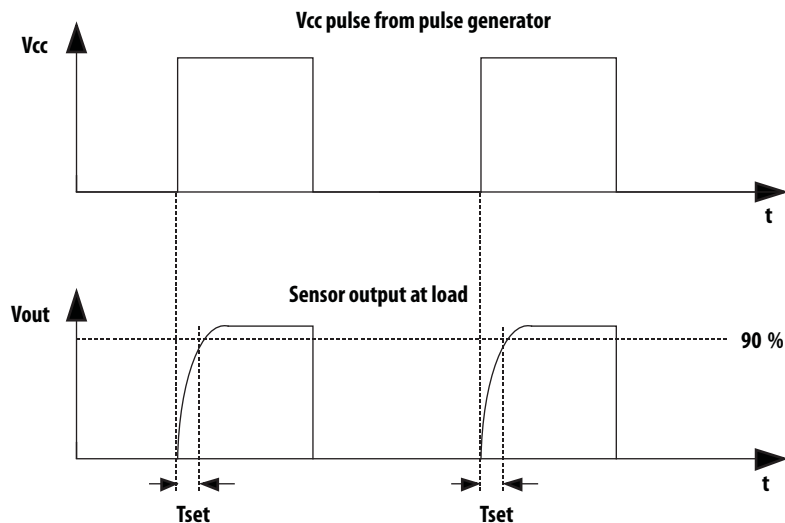
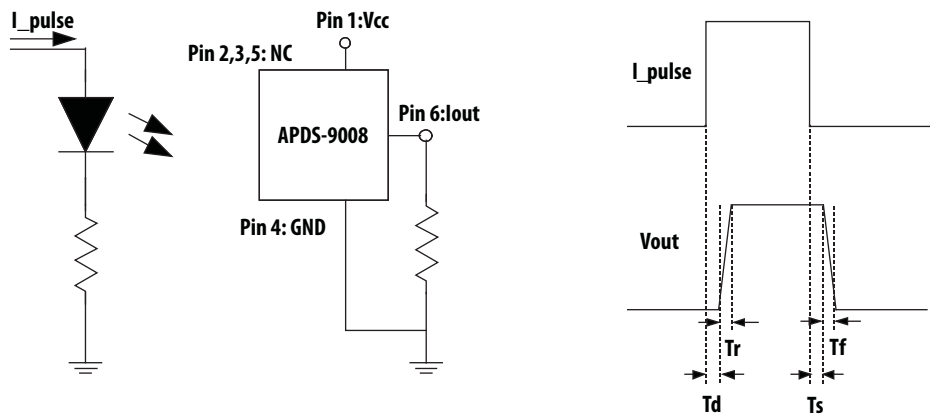

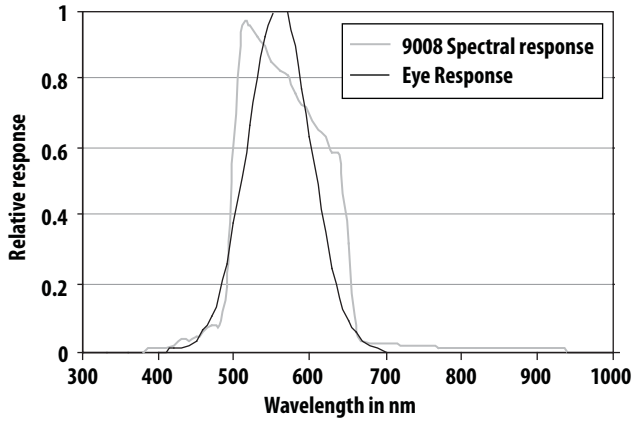

Figure 2. Relative Spectral Response Vs Wavelength

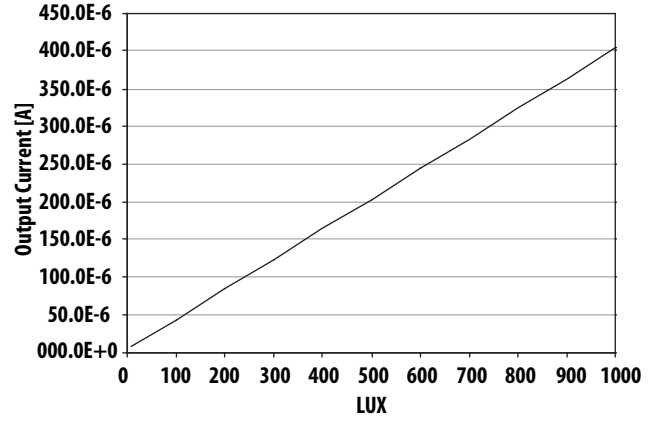

Figure 3. Average Iout Vs Lux (Vcc=1.8v, T=25°C, White LED source)

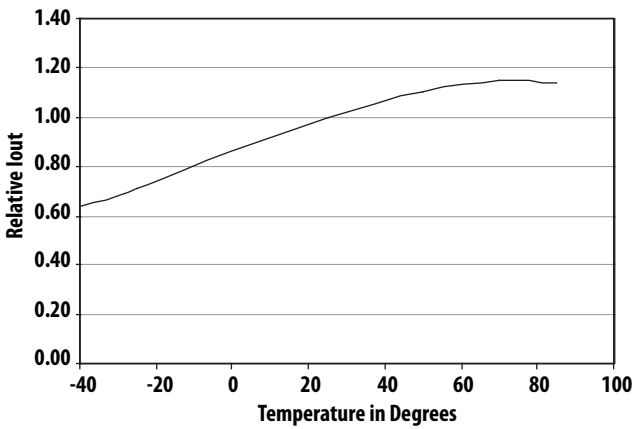

Figure 4. Relative Iout Vs Temp (Vcc=1.8v, 100 Lux)

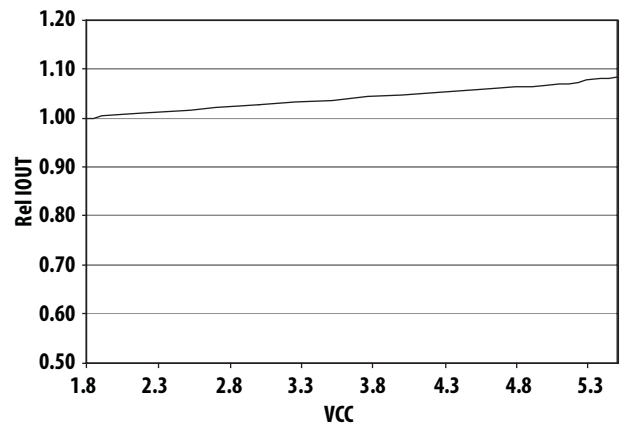

Figure 5. Relative Iout Vs Vcc (T=25°C, 100 Lux)

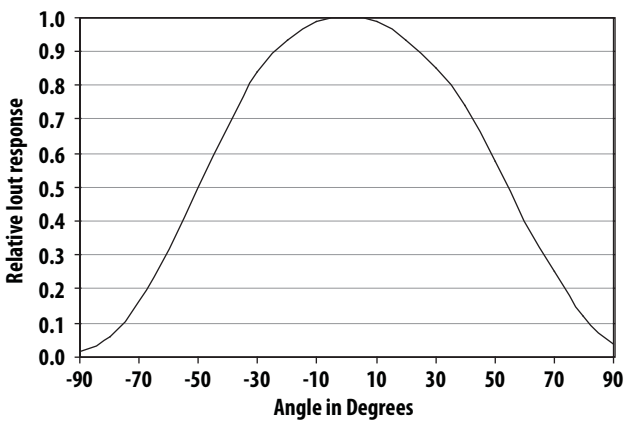

Figure 6. Relative Iout Vs Angle (Vcc=1.8v, T=25°C)

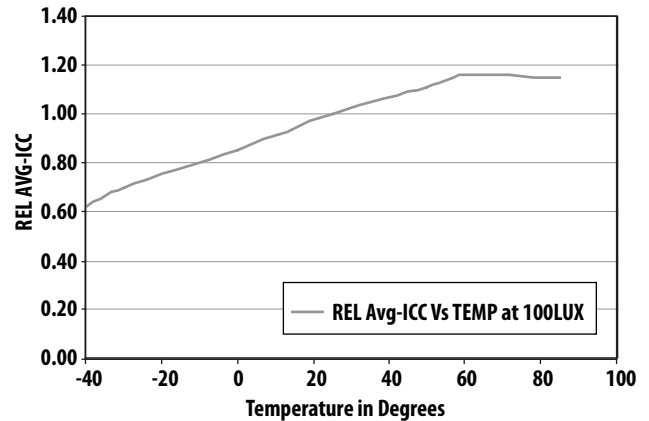

Figure 7. Relative Average Icc Vs Temp (Vcc=1.8v, T=25°C, 100 Lux)

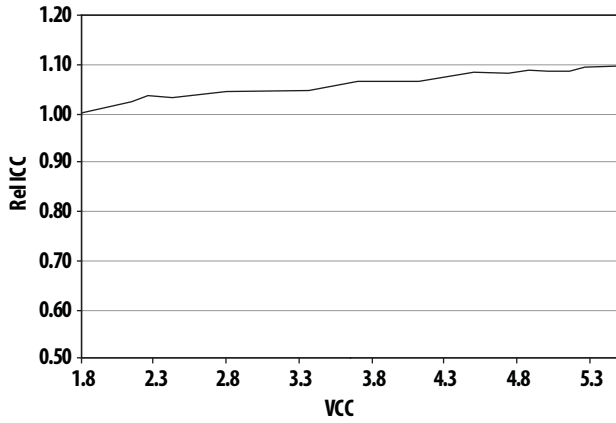

Figure 8. Relative average Icc Vs Vcc (T=25°C, 100 Lux)

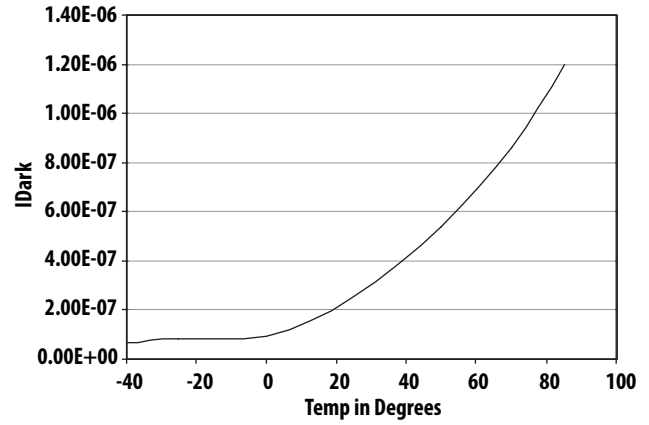

Figure 9. Dark Current Vs Temp (Vcc=1.8V)

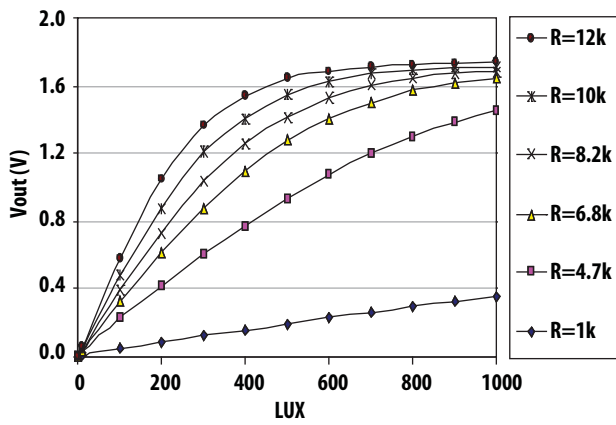
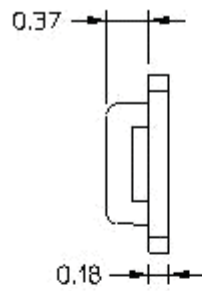
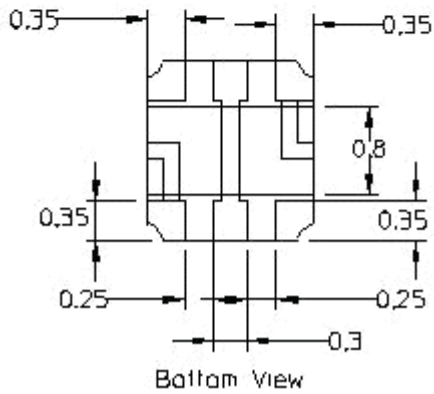
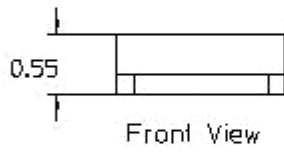
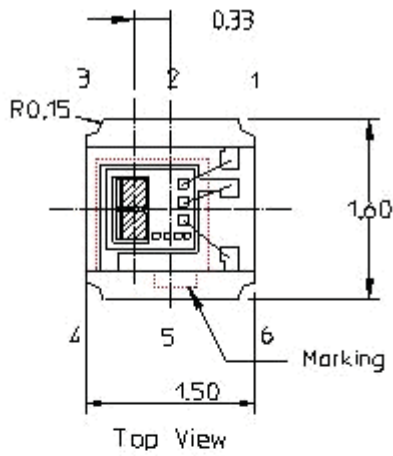

Figure 10. General Luminance Vs Typical Output Voltage (Vcc=1.8V, T=25°C, Light Source = White LED)

APDS-9008 Package Outline



Side View

Unit : mm
Tolerance : ±0.1



Light receiving area
[2 × (0.2616 × 0.2166)]mm

Pin Configuration

- 1. VCC
- 2. NC
- 3. NC
- 4. Ground
- 5. NC
- 6. OUT

APDS-9008 Tape and Reel Dimension

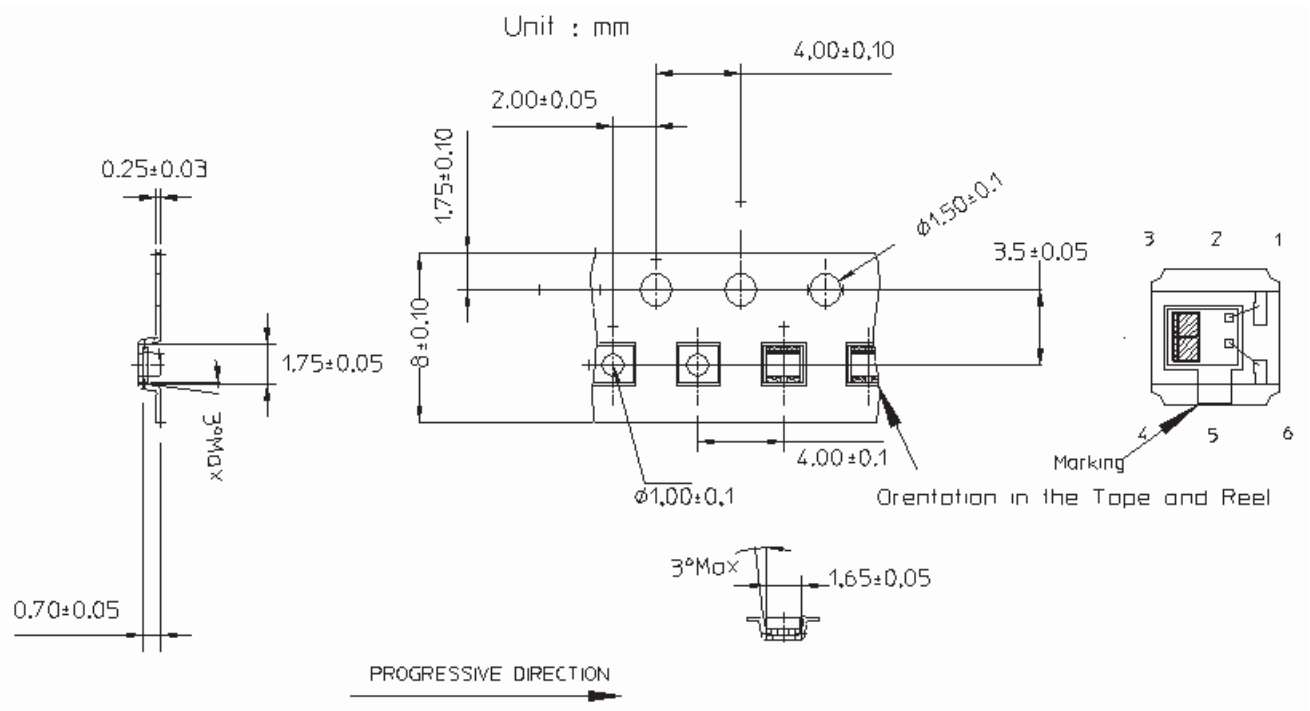

Material of Carrier Tape : Conductive Polystyrene
 Material of Cover Tape : PVC
 Method of Cover : Heat Sensitive Adhesive

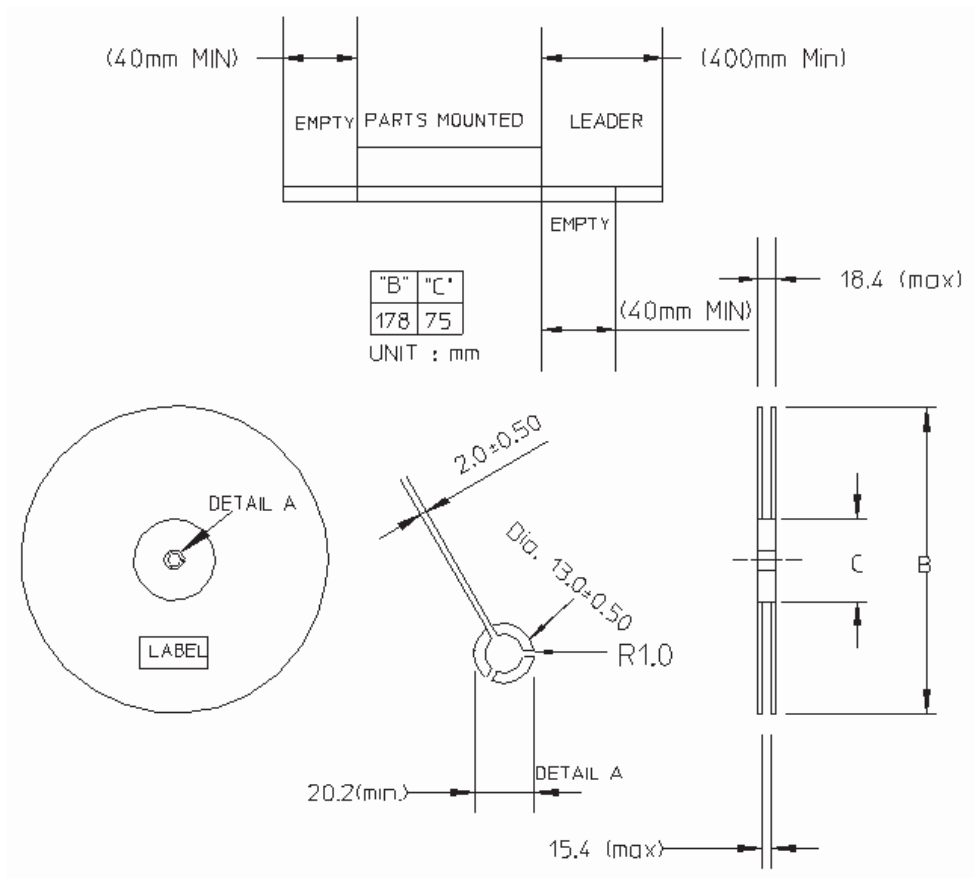

Moisture Proof Packaging

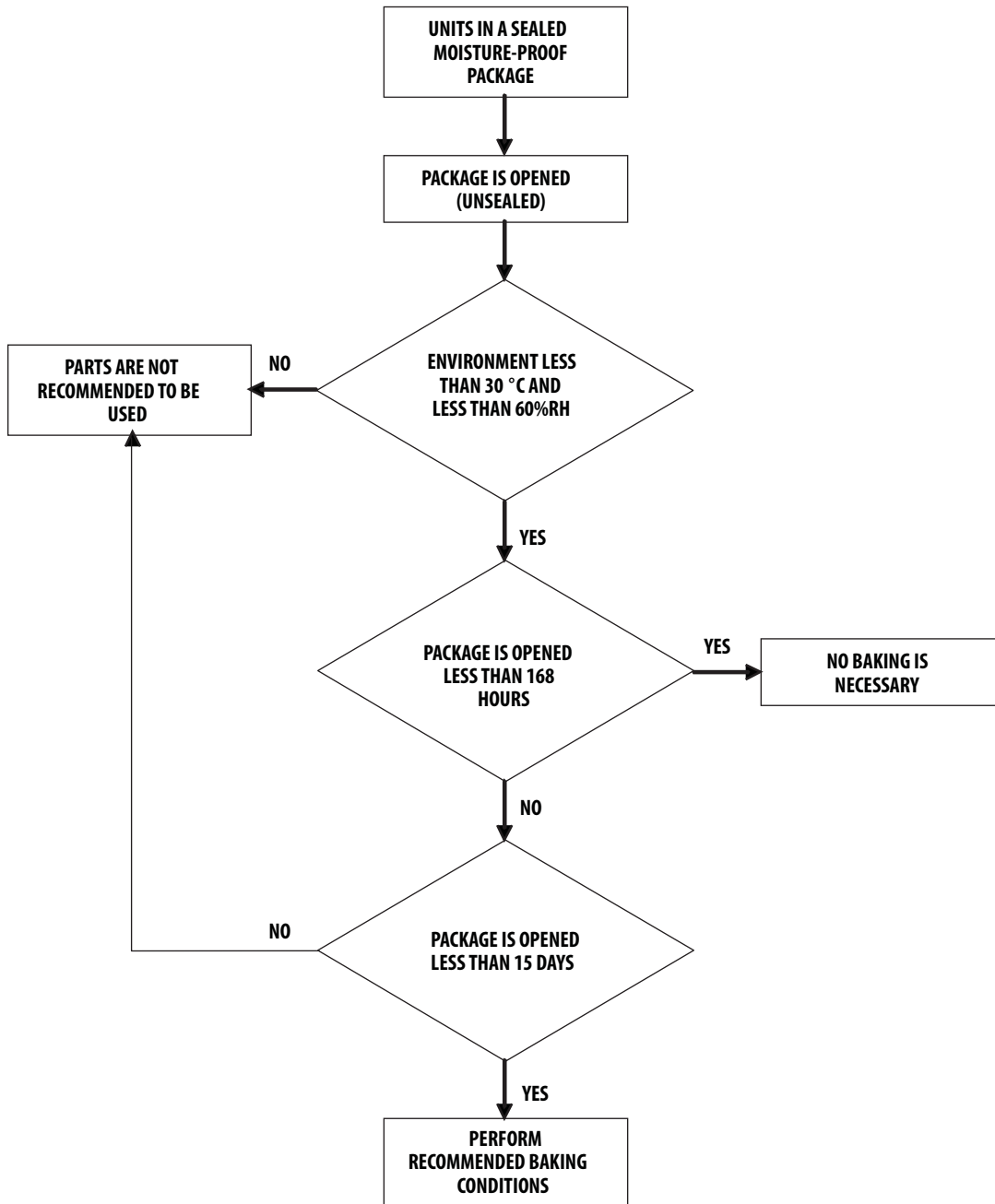

All APDS-9008 options are shipped in moisture proof package. Once opened, moisture absorption begins. This part is compliant to JEDEC Level 3.

Baking Conditions:

Package	Temperature	Time
In Reel	60°C	48 hours
In Bulk	100°C	6 hours

* Baking should only be done once.

Recommended Storage Conditions:

Storage Temperature	100°C to 300°C
Relative Humidity	below 60% RH

Time from unsealing to soldering:

After removal from the bag, the parts should be soldered within 168 hours if stored at the recommended storage conditions. If times longer than 168 hours are needed, the parts must be stored in a dry box.

Recommended Reflow Profile

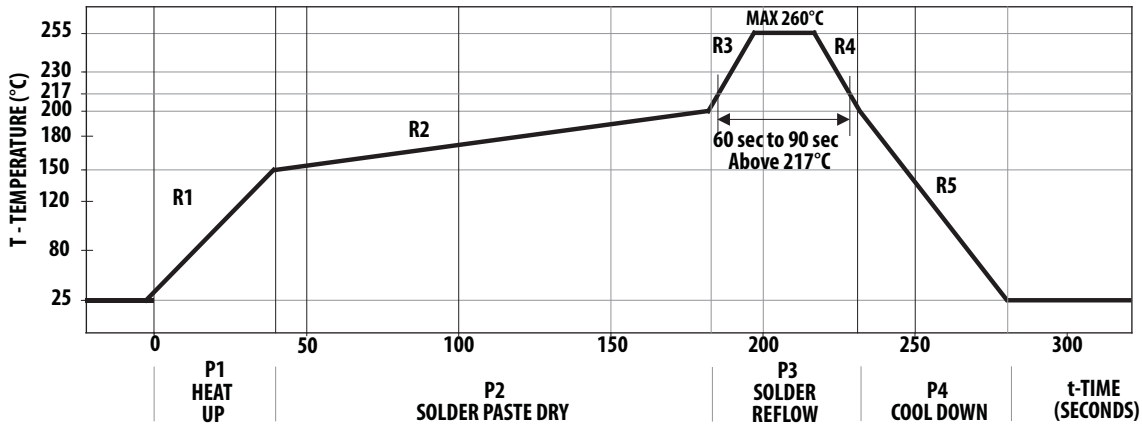

Process Zone	Symbol	ΔT	Maximum $\Delta T/\Delta \text{time}$ or Duration
Heat Up	P1, R1	25°C to 150°C	3°C/s
Solder Paste Dry	P2, R2	150°C to 200°C	100s to 180s
Solder Reflow	P3, R3 P3, R4	200°C to 260°C	3°C/s
		260°C to 200°C	-6°C/s
Cool Down	P4, R5	200°C to 25°C	-6°C/s
Time maintained above liquidus point, 217°C		> 217°C	60s to 120s
Peak Temperature		260°C	-
Time within 5°C of actual Peak Temperature		>255°C	20s to 40s
Time 25°C to Peak Temperature		25°C to 260°C	8mins

The reflow profile is a straight-line representation of a nominal temperature profile for a convective reflow solder process. The temperature profile is divided into four process zones, each with different $\Delta T/\Delta \text{time}$ temperature change rates or duration. The $\Delta T/\Delta \text{time}$ rates or duration are detailed in the above table. The temperatures are measured at the component to printed circuit board connections.

Process zone P1, the PC board and component pins are heated to a temperature of 150°C to activate the flux in the solder paste. The temperature ramp up rate, R1, is limited to 3°C per second to allow for even heating of both the PC board and component pins.

Process zone P2 should be of sufficient time duration (100 to 180 seconds) to dry the solder paste. The temperature is raised to a level just below the liquidus point of the solder.

Process zone P3 is the solder reflow zone. In zone P3, the temperature is quickly raised above the liquidus point of

solder to 260°C (500°F) for optimum results. The dwell time above the liquidus point of solder should be between 60 and 120 seconds. This is to assure proper coalescing of the solder paste into liquid solder and the formation of good solder connections. Beyond the recommended dwell time the intermetallic growth within the solder connections becomes excessive, resulting in the formation of weak and unreliable connections. The temperature is then rapidly reduced to a point below the solidus temperature of the solder to allow the solder within the connections to freeze solid.

Process zone P4 is the cool down after solder freeze. The cool down rate, R5, from the liquidus point of the solder to 25°C (77°F) should not exceed 6°C per second maximum. This limitation is necessary to allow the PC board and component pins to change dimensions evenly, putting minimal stresses on the component.

It is recommended to perform reflow soldering no more than twice.

Appendix A. SMT Assembly Application Note

1.0 Solder Pad, Mask and Metal Stencil Aperture

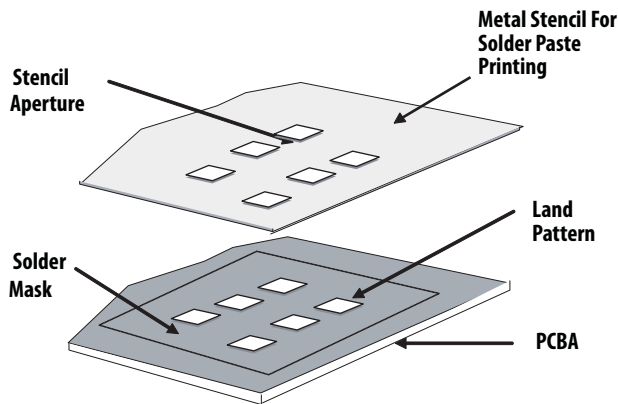

Figure A1. Stencil and PCBA

1.1 Recommended Land Pattern

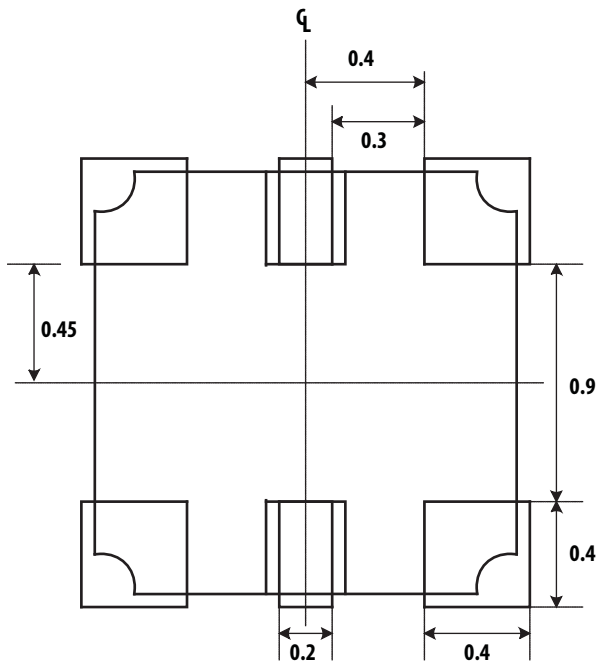

Figure A2. Recommended Land Pattern

1.2 Recommended Metal Solder Stencil Aperture

It is recommended that a 0.11 mm (0.004 inches) thick stencil be used for solder paste printing. Aperture opening for shield pad is 0.4mm x 0.4mm and 0.2mm x 0.4mm (as per land pattern). This is to ensure adequate printed solder paste volume and no shorting.

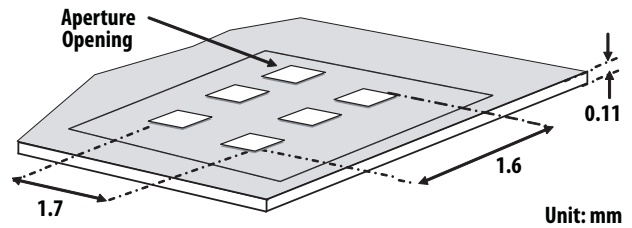

Figure A3. Solder Stencil Aperture

1.3 Adjacent Land Keepout and Solder Mask Areas

Adjacent land keep-out is the maximum space occupied by the unit relative to the land pattern. There should be no other SMD components within this area.

The minimum solder resist strip width required to avoid solder bridging adjacent pads is 0.2 mm.

Note: Wet/Liquid Photo-Imageable solder resist/mask is recommended.

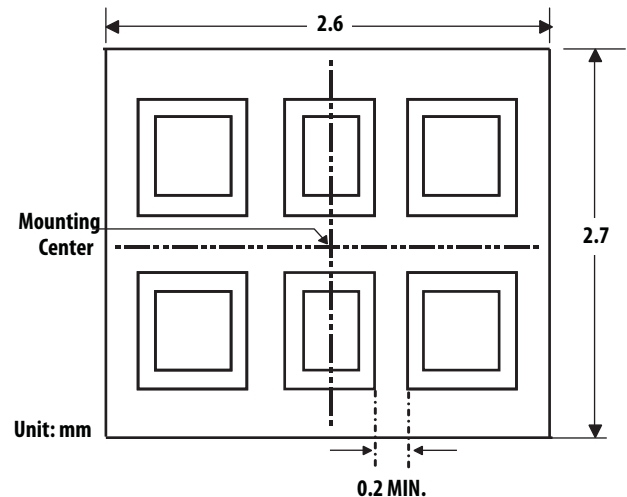

Figure A4. Adjacent Land Keepout and Solder Mask Areas

Appendix B. Optical Window Design for APDS-9008

1.0 Optical Window Dimensions

To ensure that the performance of the APDS-9008 will not be affected by improper window design, there are some constraints on the dimensions and design of the window. There is a constraint on the minimum size of the window, which is placed in front of the photo light sensor, so that it will not affect the angular response of the APDS-9008. This minimum dimension that is recommended will ensure at least a $\pm 35^\circ$ light reception cone.

If a smaller window is required, a light pipe or light guide can be used. A light pipe or light guide is a cylindrical piece of transparent plastic, which makes use of total internal reflection to focus the light.

The thickness of the window should be kept as minimum as possible because there is a loss of power in every optical window of about 8% due to reflection (4% on each side) and an additional loss of energy in the plastic material.

Figure B1 and B2 illustrate the two types of window that we have recommended which could either be a flat window or a flat window with light pipe.

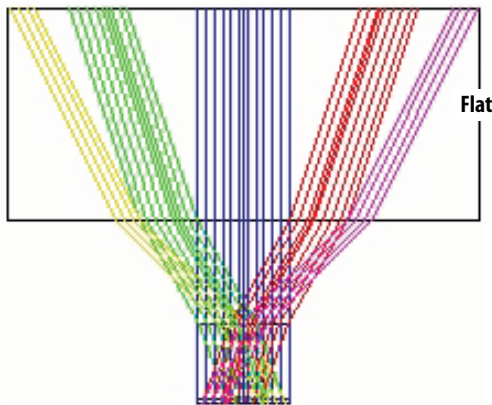

Figure B1. Window Size Determination for Flat Window

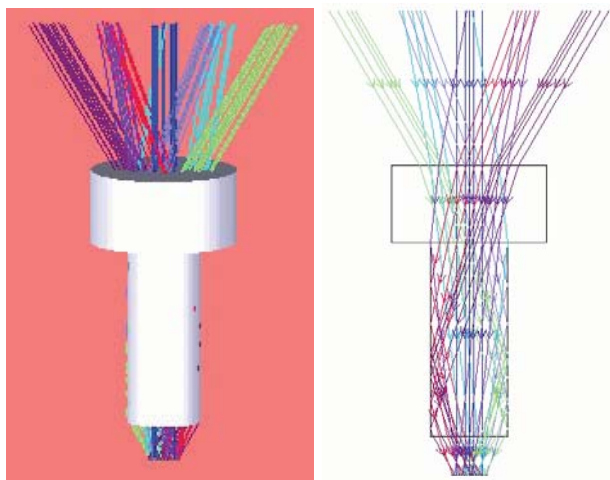

Figure B2. Window Design of Flat Window with Light Guide

Table 1 and Figure B3 below show the recommended dimensions of the window. These dimension values are based on a window thickness of 1.0mm with a refractive index 1.585.

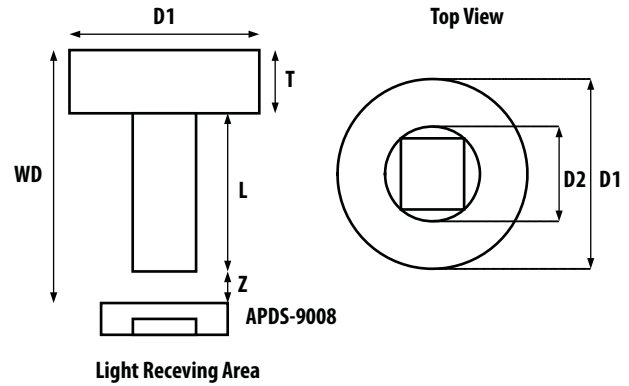

Figure B3. Recommended Window Dimensions

WD: Working Distance between window front panel & APDS-9008

D1: Window Diameter

T: Thickness

L: Length of Light Pipe

D2: Light Pipe Diameter

Z: Distance between window rear panel and APDS-9008

Table 1. Recommended dimension for optical window

All dimensions are in mm

WD (T+L+Z)	Flat Window (L=0.0)		Flat window with Light Pipe (D2=1.5; Z=0.5)	
	Z	D1	D1	L
1.5	0.5	2.25	-	-
2.0	1.0	3.25	-	-
2.5	1.5	4.25	-	-
3.0	2.0	5.00	2.5	1.5

The window should be placed directly on top of the photo sensor to achieve better performance and if a flat window with a light pipe is used, dimension D2 should be 1.5mm to optimize the performance of APDS-9008.

2.1 Optical Window Material

The material of the window is recommended to be polycarbonate. The surface finish of the plastic should be smooth, without any texture.

The recommended plastic material for use as a window is available from Bayer AG and Bayer Antwerp N. V. (Europe), Bayer Corp.(USA) and Bayer Polymers Co., Ltd. (Thailand), as shown in Table 2.

Table 2. Recommended Plastic Materials

Material number	Visible light transmission	Refractive index
Makrolon LQ2647	87%	1.587
Makrolon LQ3147	87%	1.587
Makrolon LQ3187	85%	1.587

Appendix C . General Application Guide for APDS-9008

The APDS-9008 is a low cost analog-output ambient light photo sensor whose spectral response closely emulates the human eyes. APDS-9008 consists of a photo sensor that is able to produce a high gain photo current to a sufficient level that can be converted to voltage with a standard value of external resistor. APDS-9008 can easily be integrated into systems that use ADC input which is available for sampling of the external source, as shown in figure C1 below.

The amount of converted voltage, V_{out} , is mainly dependent proportionally on the photo current which generated

by the brightness of the light shone on the photo sensor and the load resistor used, R_L . Increasing the brightness of the light or/and the load resistor will increase the output voltage.

Brightness is measured as "LUX" unit, which describes how intense a light source that our eyes perceive. LUX meter is the equipment for "LUX" measurement. Light sources with the same LUX level appear at the same brightness to the human eyes.

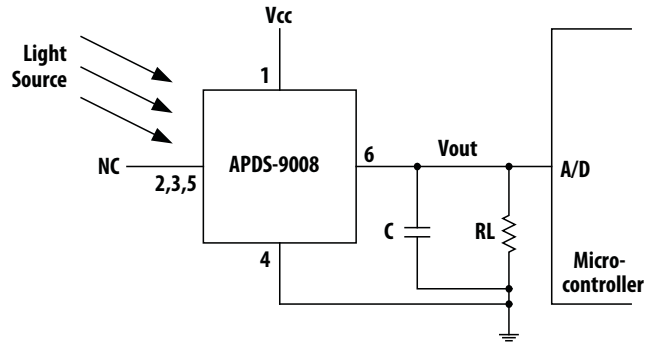

Figure C1. Configuration of APDS-9008

Selection of the load resistor R_L will determine the amount of current-to-voltage conversion in the circuit.

Light source e.g. fluorescent light consists of ac noise frequency of about 100Hz. A capacitor of 10uF, which act as a low-pass filter, is recommended to add in parallel with the load resistor to reduce the ripples.

For product information and a complete list of distributors, please go to our web site: www.avagotech.com

Avago, Avago Technologies, and the A logo are trademarks of Avago Technologies in the United States and other countries. Data subject to change. Copyright © 2005-2008 Avago Technologies. All rights reserved. AV02-1169EN - November 7, 2008

AVAGO
TECHNOLOGIES